

2007
SCOTCH STEAM
BOILERS

GENERAL - STEAM BOILERS
SCOTCH MARINE NATURAL GAS FIRED
SERIES MODEL GBS- M3- SM 7, 9.5, 10, 15 through 50 HP

SERIES GBS M3-SM-
*LN for Low Nox

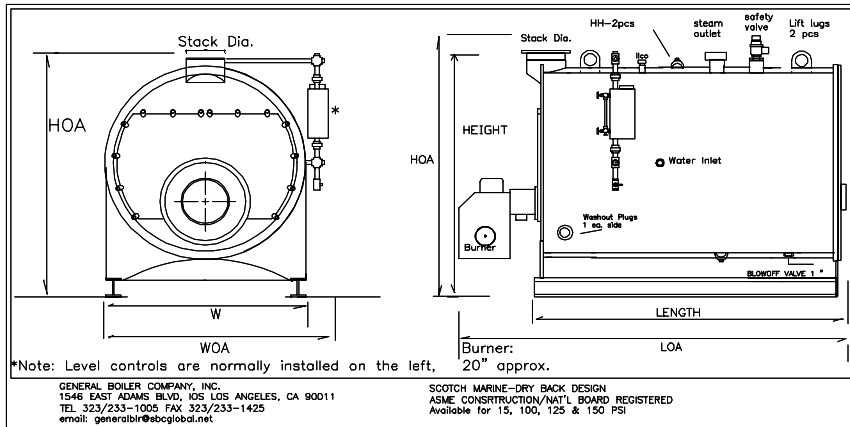

THERMAL EFFICIENCY to 85% 9.5/10

MODEL GBS-M3-SM NAT. GAS (dim. in Inches)		HP 7	HP 9.5	HP 15	HP 20	HP 25	HP 30	HP 40	HP 50
input	BTU INPUT 1,000 BTU PER HOUR	300	399	630	800	995	1260	1600	1995
	BTU OUTPUT (efficiency to 85%)	255	339	536	680	846	1071	1360	1696
	POUNDS-STEAM PER HOUR LB/HR	241	330	518	690	863	1035	1380	1725
hs	HEATING SURFACE SQ. FEET	36	60	75	110	130	150	220	275
W	WIDTH	27	33	33	34	40	40	44	52
WOA	WIDTH OVERALL (WITH LEVEL CONTROL)	32	38	38	40	46	46	50	58
L	LENGTH	48	48	48	60	60	72	96	96
LOA	LENGTH (DEPTH) INCLUDING CONTROLS(w/burner)	60	62	62	76	76	90	112	112
H	HEIGHT	38	44	44	48	48	50	54	61
HOA	HEIGHT OVERALL W/ CONTROLS	46	52	52	54	56	56	62	67
vent	VENT STACK DIAMETER	8	8	8	8	10	10	12	12
gas	GAS INLET SIZE - STD. NATURAL GAS	.75	.75	.75	1	1	1.5	1.5	1.5
	NAT. GAS MANIFOLD PRESSURE VARIABLE 3 - 4"wc								
	GAS SUPPLY PRESSURE 7 to 12 IN. W.C.								
cfh	BTU INPUT in CF/HR BASED IN 1000 BTU/CF	300	399	630	800	995	1260	1600	1995
stm	STEAM OUTLET CONNECTION 50 to 200 PSI	1	1	1	1	1	1	1.5	2
	STEAM OUTLET CONNECTION - LOW PRESSURE	1.5	1.5	1.5	2	2	2	3Fig	4Fig
s v	SAFETY RELIEF VALVE DISCHARGE 100 PSI	1	1	1	1.25	1.25	1.5	1.5	2
	SAFETY RELIEF VALVE DISCHARGE 150 PSI	1	1	1	1	1	1.25	1.25	1.5
	SAFETY RELIEF VALVE DISCHARGE 15 PSI	1	1.5	1.5	2	2	2	2	3
w in	WATER INLET SIZE	.75	.75	.75	.75	.75	.75	1	1
	WATER COLUMN DRAIN SIZE	.75	.75	.75	.75	.75	.75	.75	.75
bd	BLOWDOWN OUTLET SIZE	1	1	1	1	1	1	1.5	1.5
ele	CONTROLS-ELECTRICAL = 115 V.1Ph 16 AMPS.								
	PUMP-ELECTRICAL (2 POLES RELAY SUPPLIED)								
wt	NET WEIGHT (APPROXIMATED) LB.	1200	1600	1600	1900	2300	2800	3000	3800
	CRATED SHIPPING WEIGHT (APPROXIMATED) LB.	1300	1700	1700	2000	2500	3100	3300	4200

General Boiler Co., Inc. 1546 East Adams Blvd. Los Angeles, CA 90011 USA
Tel. 323/233-1005 Fax 323/233-1425 E-mail: sales@generalboiler.com URL: generalboiler.com

excel/Scotch Boiler 9.5 to 50hp '07 brochure

